



**Precision
Mixers**

Precision 20-Quart Mixer

Model AV-02

Standard Equipment and Features

- » Heavy Duty ½ Horse Power Motor
- » 115 Volt
- » 10.98 Amps
- » Single Phase
- » 115/60/1
- » Gear-Driven Transmission
- » 15-Minute Timer with automatic shut-off
- » 3-Speed
- » #12 Attachment Hub
- » Safety Bowl Guard
- » Bowl Lift Safety
- » Manual Bowl Lift
- » Dough Hook
- » Wire Whip
- » Beater/Paddle
- » Stainless Steel Bowl
- » Bowl Locking Handles
- » 7-Foot Power Cord
- » Counter-Top Model
- » **Industry Leading 3-Year-Limited Parts Warranty**
- » **1-Year Full Parts and Labor Warranty**



Built to Last . . . Priced to Save!

Precision North America, LLC.
60 Commerce Ave.
Albany, New York 12206



www.precisionmixers.com • Phone: 1-877-R-MIXERS (1-877-764-9377) • Fax: 518-462-3389



Specifications and Dimensions

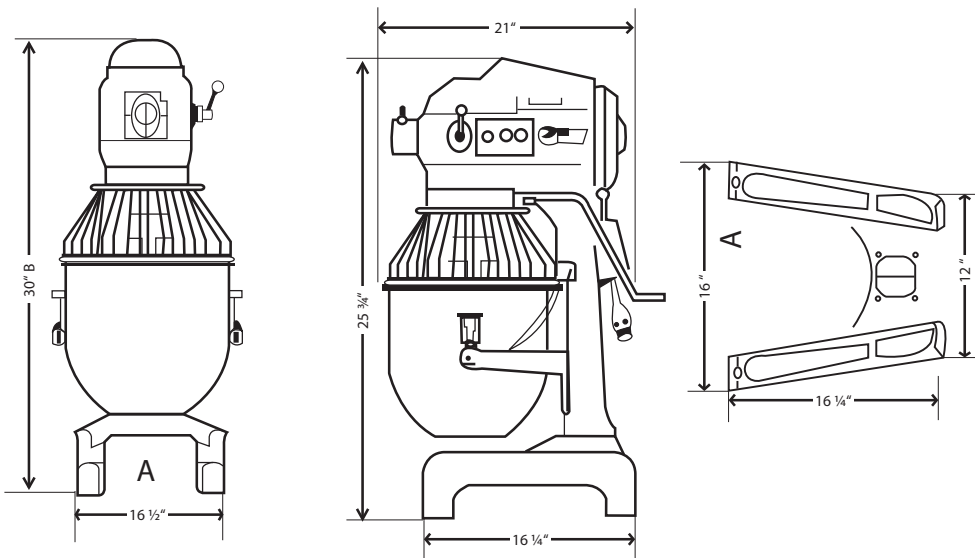

Electrical:

- 115Volt
- 1-Phase Power
- Entela Approved
- 220V, 1 or 3 phase available

Weight:

- 216 Pounds Net
- 256 Domestic shipping

Warranty:

- 3-Year Limited Parts, (Motor, Transmission, and Drive-Train).
- 1-Full Year Parts and Labor.

Amp Draw Specifications

Phase	Volts	Amps
1	115	10.98

Dimensions

Mixer Body:

- A: 16½" Wide
- B: 30" High
- C: 21" Depth

Bowl:

- Outside w/handles: 15½"
- Inside: 12⁵/₈"
- Height: 11½"

NOTE: Hub attachment not to be used while mixing

Benefits

Motor:

- Over-sized, Heavy-Duty, ½ Horse Power Motor
- Manual Reset Motor Overload

Bowl Locking Handles:

- Locks bowl in place

Attachment Hub:

- Uses standard # 12 attachments

Power Supply:

- 7" Length Power Cord

Timer:

- Automatic shutoff at desired mixing time

Easy Maintenance and Service
National Network of Service Professionals

Safety features

Bowl Guard:

- Auto shut-off when bowl guard is opened.

Lift Safety:

- Auto shut-off when bowl is lowered.

Speed	Agitator RPMs	Attachment Hub RPM's
1	76	125
2	142	248
3	259	453

Specifications are subject to change.

Precision North America, LLC.
60 Commerce Ave.
Albany, New York 12206



www.precisionmixers.com • Phone: 1-877-R-MIXERS (1-877-764-9377) • Fax: 518-462-3389