



## Standard Equipment and Features

- » 11½ Horse Power Motor
- » 208/240 Volt
- » 10 Amp draw
- » Single Phase
- » Gear-Driven Transmission
- » 30-Minute Timer with automatic shut-off
- » 3-Speed
- » #12 Attachment Hub
- » Safety Bowl Guard
- » Bowl Lift Safety
- » Dough Hook
- » Wire Whip
- » Beater/Paddle
- » Stainless Steel Bowl
- » Bowl Locking Handles
- » Bowl Stabilizer
- » **Industry Leading 3-Year-Limited Parts Warranty**
- » **1-Year Full Parts and Labor Warranty**

## Optional Accessories

- » 20-quart Knockdown Plate
- » 20-quart Bowl
- » Whip, Beater, and Hook for 20-quart Bowl

**Please specify when ordering mixer.**



## Built to Last . . . Priced to Save!

**Precision North America, LLC.**  
**60 Commerce Ave.**  
**Albany, New York 12206**



**www.precisionmixers.com • Phone: 1-877-R-MIXERS (1-877-764-9377) • Fax: 518-462-3389**



### Specifications and Dimensions

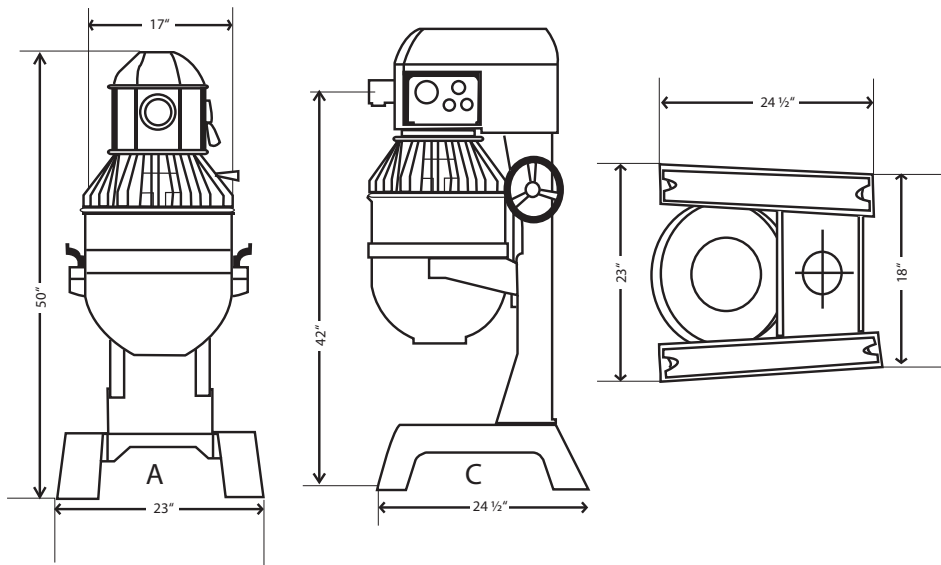

#### Electrical:

- 208/240Volt
- 1-Phase Power
- Entela Approved

#### Weight:

- 462 Pounds Net
- 562 Domestic shipping

#### Warranty:

- 3-Year Limited Parts, (Motor, Transmission, and Drive-Train).
- 1-Full Year Parts and Labor.

#### Amp Draw Specifications

Phase	Volts	Amps
1	208/240	10

#### Dimensions

##### Mixer Body:

A: 23" Wide

B: 50" High

C: 24 1/2" Depth

##### Bowl:

Outside w/handles: 21 1/2"

Inside: 15 3/8"

Height: 16 1/4"

**NOTE:** Hub attachment not to be used while mixing

#### Benefits

##### Motor:

- Heavy-Duty, 1 1/2 Horse Power Motor
- Manual Reset Motor Overload

##### Bowl Lift:

- Locks in any position

##### Bowl Stabilizer:

- Flat Exterior Bowl Base for Bowl Stability

##### Attachment Hub:

- Uses standard # 12 attachments

##### Power Supply:

- 7" Length Power Cord

##### Timer:

- Automatic shutoff at desired mixing time

**Easy Maintenance and Service  
National Network of Service  
Professionals**

#### Safety features

##### Bowl Guard:

- Auto shut-off when bowl guard is opened.

##### Lift Safety:

- Auto shut-off when bowl is lowered.

Speed	Agitator RPMs	Attachment Hub RPM's
1	55	96
2	105	183
3	230	402

Specifications are subject to change.

**Precision North America, LLC.**  
60 Commerce Ave.  
Albany, New York 12206

www.precisionmixers.com • Phone: 1-877-R-MIXERS (1-877-764-9377) • Fax: 518-462-3389

