



**Precision
Mixers**

Precision 50-Quart Mixer

Model HUB-50

Standard Equipment and Features

- » 2 Horse Power Motor
- » 208/240 Volt
- » 12.60 Amps draw
- » Single Phase
- » 208/60/1
- » Gear-Driven Transmission
- » 30-Minute Timer with automatic shut-off
- » 3-Speed
- » #12 Attachment Hub
- » Safety Bowl Guard
- » Bowl Lift Guard
- » Dough Hook
- » Wire Whip
- » Beater/Paddle
- » Stainless Steel Bowl
- » Bowl Locking Handles
- » Bowl Stabilizer
- » **Industry Leading 3-Year-Limited Parts Warranty**
- » **1-Year Full Parts and Labor Warranty**



Built to Last . . . Priced to Save!

Precision North America, LLC.
60 Commerce Ave.
Albany, New York 12206



www.precisionmixers.com • Phone: 1-877-R-MIXERS (1-877-764-9377) • Fax: 518-462-3389



Specifications and Dimensions

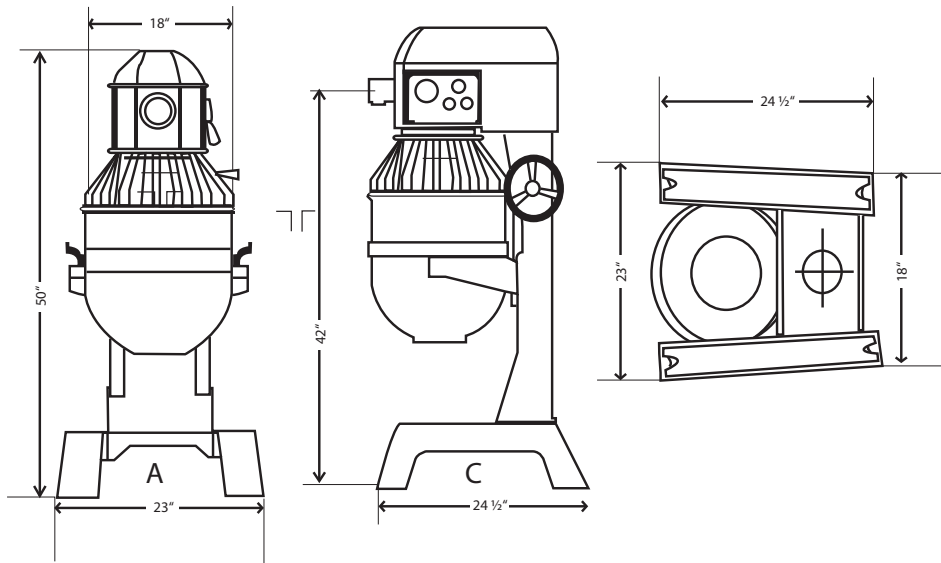

Electrical:

- 208/240Volt
- 1-Phase Power
- Entela Approved

Weight:

- 482 Pounds Net
- 584 Domestic shipping

Warranty:

- 3-Year Limited Parts, (Motor, Transmission, and Drive-Train).
- 1-Full Year Parts and Labor.

Amp Draw Specifications

Phase	Volts	Amps
1	208	14.5
1	230	12.6

Dimensions

Mixer Body:

- A: 23" Wide
- B: 50" High
- C: 24½" Depth

Bowl:

- Outside w/handles: 21½"
- Inside: 16³/₈"
- Height: 17¼"

NOTE: Hub attachment not to be used while mixing

Benefits

Motor:

- Heavy-Duty, 2-Horse Power Motor
- Manual Reset Motor Overload

Bowl Lift:

- Locks in any position

Bowl Stabilizer:

- Flat Exterior Bowl Base for Bowl Stability

Attachment Hub:

- Uses standard # 12 attachments

Power Supply:

- 6" Length Power Cord

Timer:

- Automatic shutoff at desired mixing time

**Easy Maintenance and Service
National Network of Service Professionals**

Safety features

Bowl Guard:

- Auto shut-off when bowl guard is opened.

Lift Safety:

- Auto shut-off when bowl is lowered.

Speed	Agitator RPMs	Attachment Hub RPM's
1	55	96
2	105	183
3	230	402

Specifications are subject to change.

Precision North America, LLC.
60 Commerce Ave.
Albany, New York 12206

www.precisionmixers.com • Phone: 1-877-R-MIXERS (1-877-764-9377) • Fax: 518-462-3389

